



CENTRES D'USINAGE  
VERTICAUX

VERTIKALE  
BEARBEITUNGSZENTER

VERTICAL MACHINING  
CENTERS

60  
CNC  
100  
CNC  
160  
CNC

**scemama sa**

Machines-outils / neuf et occasion - Machines-tools / second-hand  
Werkzeugmaschinen / neu und gebraucht

Route de Soleure 145  
CH-2504 Bière / Switzerland  
Tél: +41 (0)32 344 20 60  
fax: +41 (0)32 344 20 66  
www.scemama.ch/info@scemama.ch

**SCHAUBLIN** <sup>+</sup>  
MACHINES SA

Longlife High Precision



car industry



optical



micro mechanic



aeronautic aerospace



medical dental



tooling



equipments



60 CNC 100 CNC 160 CNC

Centre d'usinage verticalaux  
Vertikale Bearbeitungszenter  
Vertical machining centers

## BÂTI – BROCHES

Centres d'usinage verticalaux disponibles en trois grandeurs différentes.

Construction en fonte lourde pour renforcer la rigidité.

Châssis en «C» avec bâti en fonte largement positionné et rigide, assure l'absorption des chocs.

Vis à billes fixes, sur tous les axes, précontraintes augmentant la résistance à la chaleur.

Guides linéaires des axes X et Y.

Broche rigide et thermiquement stable avec paliers lubrifiés à vie.

## MASCHINENBETT – SPINDEL

*Vertikale Bearbeitungszentren in drei verschiedene Modelle lieferbar.*

*Massive gusseiserne Konstruktion bringt optimale Steifigkeit gepaart mit hoher Stabilität.*

*Breit angelegte „C“ Rahmen – Konstruktion mit stabilem Gusseisen*

*Untergestell nimmt die hohen Zerspanungskräfte auf.*

*Vorgespannte Kugelumlaufspindeln in allen Achsen, für erhöhte Wärmebeständigkeit.*

*X- und Y-Achsen Wälzführungen.*

*Robuste, wärmefeste Spindel mit dauergeschmierten Spindellager.*

## BASE – SPINDLE

Vertical machining centers in three different types available.

Massive cast iron construction for added rigidity.

Fixed column in “C-frame” design with wide stance, rigid cast iron base absorbs heavy cutting forces.

Fixed, pre-tensioned ball screws for increased thermal stability.

X- and Y -Axis linear guideways.

Stiff and thermally-stable spindle bearings grease lubricated for life.

FLEXIBILITY  
LONGEVITY  
HIGH PRECISION  
SPECIALITIES



60-CNC  
100-CNC



160-CNC

**BROCHES – SPINDEL – SPINDLE**



60-/ 100-CNC: 8'000 min<sup>-1</sup> / 160-CNC: 10'000 min<sup>-1</sup> (ISO 40 / ISO 50)

**OPTIONS 60-/ 100-CNC**

12'000 min<sup>-1</sup> / 15'000 min<sup>-1</sup>

8'000 min<sup>-1</sup> avec boîte à vitesses - mit ZF Getriebe - with gearbox

**OPTIONS 160-CNC - ISO 50**

6'000 min<sup>-1</sup> avec boîte à vitesses - mit ZF Getriebe - with gearbox



Arrosage par le centre (option)

Kühlmittelezufuhr durch die Spindel (Option)

Coolant through the spindle (option)

**CHANGEUR D'OUTILS – WERKZEUGWECHSLER – TOOL CHANGER**

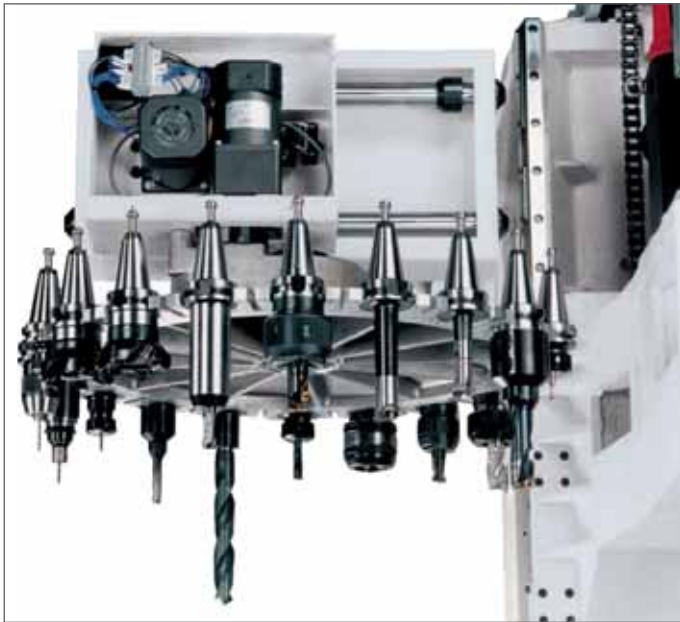

60-CNC / 100-CNC

Type carrousel 20 outils

Karussell Typ 20 Werkzeuge

Carrousel type 20 tools



VERTICAL – VERTIKALER – SWING ARM

	Standard	Option
60-CNC / 100-CNC	-	24
160-CNC ISO 40	30	40
160-CNC ISO 50	24	-

## DONNÉES TECHNIQUES

**Courses**

Longitudinale: axe X
Transversale: axe Y
Verticale: axe Z
Distance nez de broche - table
Distance centre broche - colonne

**Table**

Longueur x Largeur
Charge maximale admissible
Largeur rainures à T (nombre)
Distance entre les rainures

**Broche**

Cône de broche
Puissance du moteur
Vitesses
Couple
Force de serrage des outils

**Option**

Boîtes à vitesses
Haute vitesse
Couple boîte à vitesses
Couple haute-vitesse (12'000 min <sup>-1</sup> )

**Moteur d'axes**

FANUC
Siemens

**Avance**

Vitesses rapides (chaque axe)
Vitesse de coupe max.
Vitesse manuelle max.

**Changeur d'outils**

Carrusel capacité
Changeur vertical
Changeur vertical (option)
Cône
Diamètre max. outils
Diamètre max. avec 1 place libre
Poids max. outils
Longueur max. outils

**Copeaux à copeaux**

Carrusel-type
Changeur vertical-type

**Précision**

Positionnement
Répétabilité
Axe X
Axes Y et Z
Avec règles (option)

**Vis à billes**

Diamètre (tous les axes)
Pas (tous les axes)

**Arrosage**

Capacité du réservoir
Débit de la pompe
Arrosage par le centre 20 bars (option)
Lavage copeaux (option)

**Encombrement et poids**

Poids net approximatif
Dimensions hors tout en mm (longueur x profondeur x hauteur)

**Verfahrwege**

Längs: X-Achse
Quer: Y-Achse
Senkrecht: Z-Achse
Spindelkopf bis Tischauflage
Spindelmitte bis Säule

**Tisch**

Länge x Breite
Höchstgewicht der Stücke
Breite T-Nuten (Nummer)
Abstand der T-Nuten

**Spindel**

Spindelkonus
Motorleistung
Drehzahl
Drehmoment
Werkzeugspannkraft

**Option**

ZF-Getriebe
Hohe Geschwindigkeit
Drehmoment ZF-Getriebe
Drehmoment hohe Geschwindigkeit (12'000 min <sup>-1</sup> )

**Achsen Motoren**

FANUC
Siemens

**Vorschübe**

Eilgang (je Achse)
Schnittgeschwindigkeit max.
Schrittgeschwindigkeit max.

**Werkzeugwechsler**

Karussell Kapazität
Vertikalwechsler
Vertikalwechsler (Option)
Konus
Max. Werkzeugdurchmesser
Max. Durchmesser mit 1 freien Platz
Max. Gewicht des Werkzeuges
Max. Werkzeuglänge

**Span zu Span**

Karussell-Typ
Vertikalwechsler-Typ

**Genauigkeit**

Positionierung
Wiederholgenauigkeit:
X-Achse
Y- und Z-Achse
Mit Massstäben (Option)

**Kugelumlaufspindel**

Durchmesser (alle Achsen)
Steigung (alle Achsen)

**Kühlmittelzufuhr**

Fassungsvermögen des Tanks
Pumpenförderleistung
Innenkühlung der Werkzeuge 20 Bars (Option)
Spänespülung (Option)

**Abmessungen und Gewicht**

Nettogewicht
Maschinenabmessungen in mm (Länge x Tiefe x Höhe)

 Les Centres d'usinage verticaux 60-/100-/160-CNC sont conformes aux directives de sécurité édictées par la Communauté Européenne.  
En raison des améliorations constantes apportées à nos produits, nous ne pouvons garantir l'exactitude des données techniques, dimensions et poids figurant dans ce prospectus.

 Die vertikalen Bearbeitungszentren 60-/100-/160-CNC entsprechen den von der Europäischen Gemeinschaft (EG) erlassenen Sicherheits-Vorschriften.  
Unsere Produkte werden laufend den Marktbedürfnissen angepasst, daher sind alle Abbildungen, technische Daten, Abmessungen und Gewichtsangaben unverbindlich.

**TECHNICAL DATA**

	60-CNC	100-CNC	160-CNC
<b>Travels</b>			
Longitudinal: X-Axis	600 mm	1'020 mm	1'600 mm
Transversal: Y-Axis	540 mm	540 mm	700 mm
Vertical: Z-Axis	540 mm	540 mm	635 mm
Distance spindle nose - table surface	155 → 695 mm	155 → 695 mm	155 → 790 mm
Distance spindle center - column	584 mm	584 mm	725 mm
<b>Table</b>			
Length x Width	750 x 540 mm	1'120 x 540 mm	1'700 x 700 mm
Max weight on table	700 kg	700 kg	1'500 kg
Width T-slots (number)	18 mm (3)	18 mm (3)	18 mm (5)
Center distance (pitch)	160 mm	160 mm	125 mm
<b>Spindle</b>			
Taper size	BT 40 / ISO 40	BT 40 / ISO 40	BT 40 / ISO 40&50 / SK 40
Motor power	13 kW	13 kW	26 kW
Speed range	8'000 min <sup>-1</sup>	8'000 min <sup>-1</sup>	6'000 min <sup>-1</sup> / 10'000 min <sup>-1</sup>
Torque	82,7 Nm (1'500 min <sup>-1</sup> )	82,7 Nm (1'500 min <sup>-1</sup> )	149 Nm (1'669 min <sup>-1</sup> ) *
Tool clamp force	800 kg	800 kg	1'200 kg
<b>Option</b>			
Gearbox	8'000 min <sup>-1</sup>	8'000 min <sup>-1</sup>	—
High speed	12'000 / 15'000 min <sup>-1</sup>	12'000 / 15'000 min <sup>-1</sup>	—
Torque with gearbox	330 Nm (375 min <sup>-1</sup> )	330 Nm (375 min <sup>-1</sup> )	—
Torque with high speed (12'000 min <sup>-1</sup> )	55,2 Nm (2250 min <sup>-1</sup> )	55,2 Nm (2250 min <sup>-1</sup> )	—
<b>Axis Motor</b>			
FANUC	1,6 kW	1,6 kW	4 kW
Siemens	2,29 kW	2,29 kW	4,9 kW
<b>Feed</b>			
Rapid rates (each axis)	30 m/min	30 m/min	36 m/min
Cutting feed rate max.	12 m/min	12 m/min	12 m/min
Jog feed rate max.	30 m/min	30 m/min	36 m/min
<b>Tool Changer (ATC)</b>			
Standard carousel capacity	20	20	—
Swing arm capacity	—	—	24 / 30
Swing arm capacity (option)	24	24	40
Shank type	BT 40 / ISO 40	BT 40 / ISO 40	BT 40 / ISO 40&50 / SK 40
Tool diameter max.	89 mm	89 mm	76,2 mm
Diameter with adjacent pots empty	152,4 mm	152,4 mm	150 mm
Tool weight max.	6 kg	6 kg	8 kg
Tool length max.	250 mm	250 mm	350 mm
<b>Chip-to-chip</b>			
Carousel-type	6,5 - 8,5 secondes	6,5 - 8,5 secondes	—
Swing arm-type	2,5 - 4,5 secondes	2,5 - 4,5 secondes	2,5 - 5,0 secondes
<b>Accuracy</b>			
Positioning	+/- 0,005 mm	+/- 0,005 mm	+/- 0,007 mm
Repeatability: X-Axis	0.002 mm	0.002 mm	0.007 mm
Y and Z Axis	0.002 mm	0.002 mm	0.007 mm
With linear scale on all axis (option)	0.002 mm	0.002 mm	0.007 mm
<b>Ball screws</b>			
Diameter (all axis)	32 mm	32 mm	45 mm
Pitch (all axis)	10 mm	10 mm	12 mm
<b>Coolant supply</b>			
Tank capacity	231 l.	360 l.	400 l.
Pump capacity	50 l/min.	50 l/min.	50 l/min.
Coolant through spindle 20 bars (option)	OUI / JA / YES	OUI / JA / YES	OUI / JA / YES
Coolant chip flush system (option)	OUI / JA / YES	OUI / JA / YES	OUI / JA / YES
<b>Dimensions and weight</b>			
Net weight	5'260 kg	5'500 kg	9'400 kg
Overall dimensions in mm (length x depth x height)	2'266 x 2'292 x 2'713	2'955 x 2'190 x 2'713	3'898 x 2'581 x 2'888

 \* avec / mit / with 10'000 min<sup>-1</sup> ISO 40

 60-/100-/160-CNC Vertical machining center are in conformity with the European Community safety regulations.

In view of the constant improvements made to our products, technical data, dimensions and weights appearing in this leaflet are subject to change without notice.

DIVERSES OPTIONS – VERSCHIEDENE OPTIONEN – VARIOUS OPTIONS



Évacuateur de copeaux  
Späneförderer  
Chip conveyor



RENISHAW

Mesure de la pièce  
Werkstückmessung  
Piece measurement

Mesure de l'outil  
Werkzeugmessung  
Tool measurement



Règles de mesure – Glassmaßstäbe – Measuring scales

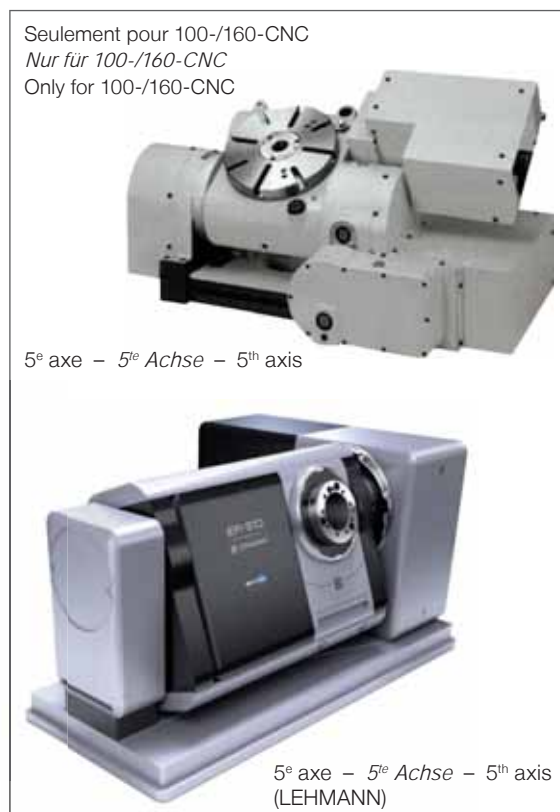

Seulement pour 100-/160-CNC  
Nur für 100-/160-CNC  
Only for 100-/160-CNC

5<sup>e</sup> axe – 5<sup>te</sup> Achse – 5<sup>th</sup> axis

5<sup>e</sup> axe – 5<sup>te</sup> Achse – 5<sup>th</sup> axis  
(LEHMANN)



4<sup>e</sup> axe – 4<sup>te</sup> Achse – 4<sup>th</sup> axis

4<sup>e</sup> axe – 4<sup>te</sup> Achse – 4<sup>th</sup> axis  
(LEHMANN)

## Commandes – Steuerungssystem – Control units



FANUC Oi MD



Générateur manuel d'impulsions inclus  
*Impulsgeber in Normalausführung*  
Manual Pulse Generator included



Siemens 810D / 828D

### FANUC Oi CONTROL UNIT

Graphic with dialog function

- Ease of operation and many standard features with the FANUC Oi Control with 8.4" LCD display.
- Additional Coordinate Select (48 pair, 54 Total)
- Angle Chamfering/Comer rounding
- Background Editing
- DNC (remote buffer)
- Helical Interpolation
- Polar Coordinate Command
- Registered Part Program Storage (200)
- Run Time Parts Count
- Self-Diagnostic Function
- Tool Offsets (400)
- RS-232 Software/Hardware
- Operator's panel is designed to be user-friendly, especially in the placement of buttons and identifying nomenclature
- Mylar panel keyboard provides exceptional reliability
- Axis inhibit
- Cycle Start
- Feed Hold
- Jog Feed
- Program protect (in control)
- Remote Manual Pulse Generator (MPG)
- Spindle Speed Jog Override (CW/CCW in jog mode)
- Interlocking guard doors help assure safe and efficient operation of the machine
- Alarm Display
- Auto Corner Override
- Custom Macro B
- Expanded Part Program Edit (copy/replace)
- Ladder Diagram Display
- Programmable Mirror Image
- Rigid Tapping
- Scaling
- Single Direction Positioning

- 640 Meters of Control Memory (256 kb)
- Block Delete
- Coolant Control
- Emergency Stop
- Feed Override
- Option Stop
- Rapid Traverse Override
- Spindle Speed Override (in auto mode)
- Manual Guide Oi + Dynamic Graphic Display

### SIEMENS SINUMERIK 828 CONTROL UNIT WITH SHOPMILL

- Basic quantity of axes/spindles/auxiliary axes (4)
- Max. configuration axes/spindles/auxiliary axes (6)
- Max. number of interpolating axes (4)
- Max. number of machining channels (1)
- Minimum block cycle time (2 ms)
- CNC user memory (3 MByte)
- Tool management with monitoring of tool life and workpiece count
- Max. number of tools/cutting edges (128/256)
- Number of settable zero-offset (100)
- Asynchronous subroutines ASUB
- Synchronized actions and high-speed auxiliary function output
- Acceleration with jerk limitation
- Look Ahead (number of blocks) (100)
- Compressor for 3-axis machining
- Advanced Surface
- Travel fixed stop
- Temperature compensation
- Programming language
- Online ISO dialect interpreter
- Technology cycles for drilling and milling
- Programming support for technology cycles (ProgramGuide)
- Simulation in plane display
- Integrated PLC based on SIMATIC S7-200

- Ladder viewer and add-on editor on board
- Processing time per PLC command (0.025µs)
- Max. number of PLC ladder steps (24000)
- Servo-synchronous High Speed PLC Task
- Reaction time to process events (7.5ms)
- Max. number of digital inputs/outputs (288/192)
- Max. number of analogue inputs/outputs (8/8)
- Service Planner
- Easy extend
- Easy archive

### OPTION SIEMENS

- Each additional axis/spindle
- Replacement tools
- A, B, C spline interpolation
- Transmit and peripheral surface transformation
- Travel to fixed stop with force control
- Pair of synchronized axes Gantry
- Bidirectional leadscrew error compensation
- Multi-dimensional sag compensation
- Residual material detection and machining
- ShopTurn/ShopMill machining step programming
- Measuring cycles for drilling/milling and turning
- Simulation in 3D display
- Simultaneous recording
- Extended operator functions for complex turning and milling tasks
- Contour handwheel
- Network drive management
- Remote diagnostics function RCD host
- PLC periphery modules PP 72/48D PN
- PN/PN coupler
- Easy Screen

**NOS PRODUITS**

Tournage / fraisage

**UNSERE PRODUKTE**

Drehen / Fräsen

**OUR PRODUCTS**

Turning / Milling



**Machine range 136/137**  
Centre de tournage et de production  
Hochpräzisions-Produktions-Drehcenter  
High precision and production turning center



**51-5AX**  
Centre d'usinage vertical - 5 axes simultanés  
Vertikale Bearbeitungszenter - 5 Simultan Achsen  
Vertical Machining Center - 5 simultaneous axis



**60-CNC / 100-CNC / 160-CNC**  
Centres d'usinage verticaux  
Vertikale Bearbeitungszenter  
Vertical Machining Centers



**48V / 48V-15K / 48 APC**  
Centres d'usinage verticaux compact  
Kompakt Vertikale Bearbeitungszenter  
Compact vertical machining centers



**102 TM-CNC**  
Tour CNC de haute précision  
CNC Hochpräzisions-Drehmaschine  
High Precision CNC lathe



**180-CCN**  
Tours CNC de haute précision  
CNC Hochpräzisions-Drehmaschinen  
High Precision CNC lathe



**125-CCN**  
Tours CNC de haute précision  
CNC Hochpräzisions-Drehmaschinen  
High Precision CNC lathe



**225 TM-CNC**  
Tour CNC de haute précision  
CNC Hochpräzisions-Drehmaschine  
High Precision CNC lathe



**225 Tmi-CNC**  
Tour CNC de haute précision  
CNC Hochpräzisions-Drehbanke  
High Precision CNC lathe



**102N-CF / 102Mi-CF**  
Tours conventionnel de haute précision (socle)  
Konventionelle Hochpräzisions-Drehbanke  
(Gußkastenfuß)  
High Precision conventional Lathes (Cast Iron)



**102N-CF / 102Mi-CF**  
Tours conventionnels de haute précision (établi)  
Konventionelle Hochpräzisions-Drehbanke (Werkbank)  
High Precision conventional Lathes (Bench)



**102N-VM-CF**  
Tour conventionnel de haute précision (socle)  
Konventionelle Hochpräzisions-Drehmaschine  
(Gußkastenfuß)  
High Precision conventional Lathe (Cast Iron)



**70-CF / 70Mi-CF**  
Tours conventionnels de haute précision (établi)  
Konventionelle Hochpräzisions-Drehbanke (Werkbank)  
High Precision conventional Lathes (Bench)

Votre partenaire / Ihr Partner / Your partner :



Machines-outils / neue und occasion - Machines-werkzeu / second-hand  
Werkzeugmaschinen / neu und gebraucht

Route de Schiers 145  
CH-2504 Bière / Switzerland  
Tel: +41 (0)32 344 20 60  
fax: +41 (0)32 344 20 66  
www.scemama.ch info@scemama.ch